

Promat



PROMATECT® 100
Self-supporting Ceiling Membrane – Type 2



Introduction

Promat carries a wide range of fire rated ceiling and floor systems with fire resistance of up to 240 minutes. Generally, PROMATECT® ceiling and floor systems provide horizontal fire barriers to prevent vertical spread of fire.

PROMATECT® ceiling and floor systems have been extensively tested and assessed to provide resistance to fire from above, below or above and below. They satisfy the integrity and insulation criteria of BS476: Parts 20, 21, 22 and 23: 1987 and/or AS 1530 Part 4. The flooring systems not only meet the integrity and insulation criteria but also meet the loadbearing capacity (structural adequacy) criteria of the British and Australian national standards.

The system design depends on performance requirements but in overall terms, PROMATECT® ceiling and floor systems can be divided into the following categories.

1. Self-supporting Membrane Ceilings

These are normally non-loadbearing and, depending on the type of construction, are used to provide protection from fire attack from below and/or above. Ceiling panels are fixed into a steel or timber framing system spanning and supported between two walls.

Self-supporting membrane ceilings should normally be tested or assessed in accordance with BS476: Part 22 and/or AS1530: Part 4 to satisfy the failure criteria of integrity and insulation.

These ceiling systems allow for the protection to or from services contained within the ceiling void. They will also provide protection to steel beams that are required to meet the criteria of BS476: Part 23 where exposure to fire is from below.

2. Suspended Membrane Ceilings

These are normally non-loadbearing and are used to provide protection from fire attack from below. The ceilings generally incorporate steel grid systems suspended from a structure.

Suspended membrane ceilings should normally be tested or assessed in accordance with BS476: Part 22 and/or AS1530: Part 4 to satisfy the failure criteria of integrity and insulation.

These ceiling systems allow for the protection to or from services contained within the ceiling void. They will also provide protection to steel beams that are required to meet the criteria of BS476: Part 23 where exposure to fire is from below.

3. Loadbearing Floor Systems

The flooring can be of timber or chipboard floorboards supported by either timber joists or steel joists system. PROMATECT® boards can be directly fixed onto these joists or fixed to a suspended exposed or concealed metal grid system.

This type of ceiling should normally be tested or assessed in accordance with BS476: Part 21 and/or AS1530: Part 4 and are required to satisfy the three failure criteria of loadbearing capacity (structural adequacy), integrity and insulation.

4. Suspended Ceiling Protection To Steel Beams

This type of ceiling is used mainly for protection of steel beams supporting a loadbearing concrete floor slab and should be tested or assessed to BS476: Part 23 and AS1530: Part 4. PROMATECT® boards are fixed to a metal exposed or concealed grid system suspended from the structure above.

Advantages

PROMATECT® ceiling and floor systems require less material to achieve similar fire resistant levels when compared to the industry average. This can lead to more simplified construction methods than the standard equivalent. Use of PROMATECT® therefore helps to increase productivity and reduce overall installation costs.

PROMATECT® ceiling and floor systems have been developed by Promat International to satisfy standard requirements for internal applications. Benefits include:

Time & Cost Effectiveness

Simple construction methods reduce installation cost and time compared to traditional systems.

Lightweight

Lighter loads on structures compared to industry average systems for equivalent fire rating.

Thermal Resistance

Excellent thermal resistance performance.

Design Flexibility

Lighter weight allows increased ceiling span, reduced support structure sizes and/or reduced system thickness.

Acoustic Performance

Tested and assessed to ISO140-3 1995 and ISO717-1 1996 to meet the needs of the industry. Please refer to [pages 5 and 6](#) for details.

Board Fixing

Longitudinal board joints must coincide with framing members. If the boards are in one layer, the transverse joints must be backed with fillet strips made of PROMATECT® boards or timber noggings for traditional timber joist construction. For boards laminated in two layers, the joints must be staggered by at least 500mm.

PROMATECT® boards may be fixed to the steel members using No.8 "Bugle" head self-drilling and self-tapping screws. No.8 woodscrews shall be used to fix boards to timber frame. For boards laminated in two layers, the outer layer boards may be stitched to the preceding layer with No.10 laminating screws. PROMATECT®-S may be fixed to the steel framework using M5.5 self-tapping/drilling Tek screws.

Minimum edge distance to fasteners and the maximum spacing between screws must be maintained. Please refer to system detail for screw spacing requirements.

General Design Considerations

The following are some of the factors which should be considered when determining the correct specification to ensure a ceiling or a floor system provides the required design performance under both fire and ambient conditions. Further advice is readily available from a local Promat office.

1. Supporting Structure Design

The design of the framing system should be adequate for the design loads of the ceiling and floor. PROMATECT® systems have been designed for timber or steel framing as described in the system specification.

For timber framing system used in loadbearing floor application, it must be designed in accordance with BS5268, AS1720.1 and/or AS1684. The width, the depth and the spacing of the joists have to be carefully specified to ensure that the timber floor will serve its intended fire performance.

For steel framed ceiling systems, it is critical to adhere to the dimension of the steel sections, the grid spacing, the suspension members (if any) and the fastening methods employed. Framing members could change depending on the factors such as ceiling span, movement and deflection and local regulations.

Larger or more frequent frame sections can often improve the fire and structural performance. The framing for the ceiling systems must be securely fixed back to a substrate that has an equal or greater fire performance than the ceiling. All fixings must be non-combustible and must be similar to those listed in the approval documents.

2. Non Loadbearing Ceilings

Non loadbearing PROMATECT® ceiling systems can be generally divided into steel frame suspended ceiling and self-supporting membrane ceiling. The steel framing as noted in the system specification is appropriate for the given span. Larger dimension of steel sections or more frequent spacing will be required for a ceiling span larger than specified.

At wall connections, mechanical joints are required and these joints must be carefully designed so that they accommodate the required expansion of steel at elevated temperature.

Non-loadbearing ceilings in this handbook are not trafficable. Trafficable ceilings for maintenance purposes can be designed. Further advice on such designs can be obtained from the Promat Technical Department.

3. Loadbearing Ceilings

There are two types of PROMATECT® loadbearing floor systems available. One is comprised of timber joists while the other is of steel joists. Flooring material, timber type, thickness and jointing are all critical. Timber framing shall be of solid timber and must be designed in accordance with BS5268, AS1720.1 and/or AS1684 whereas for steel framing, the members should be designed in accordance with BS5950 and/or AS4600.

4. Acoustics

Ceiling and floor systems have been developed to also meet specific acoustic requirements. These include ratings for sound transmission, sound impact and sound absorption. Please refer to [pages 6 and 7](#) for further information.

5. Movement Joint

Movement stress from dimensional changes due to varying temperature or moisture conditions can cause cracking and other symptoms of distress in ceiling linings.

Other external forces such as impact or vibration can directly affect structural movement of ceilings. This movement can be controlled through a variety of design techniques such as introducing perimeter relief and slip connections to reduce the transfer of stress from the structure to other building sub-elements and/or through the use of expansion joints, control joints and construction joints.

Expansion joints are needed when a ceiling abuts a rigid mass. Where ceiling dimensions exceed 10m in either direction, a control joint should be used. Control joints should also be located to intersect column penetrations, light fixtures and air diffusers. It is however, the introduction of a control joint into a fire-rated system when an opening for flame and temperature transmission is created. This and similar openings have to be properly treated with approved Promat fire-stopping material.

6. Caulking & Service Penetrations

To maintain the fire performance and, where applicable, the acoustic performance of the ceiling system, perimeter and other gaps must be appropriately filled with suitable caulking material. PROMASEAL® AN Acrylic Sealant or other tested fire and acoustic rated material of equivalent or better performance must be used.

Care needs to be taken in detailing a suitable fire-stopping system around any penetration of the ceiling by services to ensure:

- a) the fire-stopping material remains in situ,
- b) fire and smoke do not penetrate the floor cavity which ultimately will lead to,
- c) premature collapse of the joists and/or penetration of fire and smoke through the timber flooring.

Allowance should be made for thermal movement of the services in both ambient and fire conditions to ensure loads are not applied to the ceiling assembly. Some examples of service penetrations include those penetrations by electrical cables, conduits or wires, plastic and metal pipes, air-conditioning and ventilation ductwork. Further guidance on the sealing of service penetrations can be obtained from [page 8](#).

7. Light Fittings

Light fittings located within a ceiling cavity should normally be enclosed in an adequately supported fire protection box to prevent fire spreading rapidly into the ceiling cavity. Most light fittings will require ventilation in normal use and this consideration should certainly be factored into light box design. Please consult Promat for details.

8. Access Panels & Hatches

Where access into a ceiling void is required, panels and hatches will need to be installed. Please refer to separate PDFs for this area or consult Promat Technical Department for details.

9. Resistant To Impact

PROMATECT®-H offers a particularly robust system which is highly resistant to impact and abrasion. The high strength of PROMATECT®-S permits light loads such as the foot traffic of maintenance personnel. PROMATECT®-S ceiling systems are highly resistant to impact and provide excellent resistance to high pressure hose streams during fire.

Conclusion

Most building regulations stipulate limitations on the use of fire protecting suspended ceilings in certain situations. Care should be therefore taken that the use of a suspended ceiling system is acceptable to the approval authorities.

Steel Frame Components

Components Selection

In order to maintain the fire and acoustic performance of PROMATECT® ceiling systems, the type of profile used for framing is important. Construction of the PROMATECT® fire rated steel framed ceilings can be achieved using standard steel section components. Steel framing may be C or I-sections, furring channels, top hats, trusses or similar members which in all cases should be designed in accordance with BS5950, AS4600 and/or equivalent standard.

The profiles described in the system specification should be adhered to at all times. However, the profiles may be amended as long as they possess comparable performances to the specified profiles.

Perimeter Tracks & Steel Joists For Self-supporting Ceilings

This system is the most appropriate especially in situations where it is difficult to install a suspended ceiling and/or within narrow rooms or corridors. No hangers are required for this system, producing shorter installation times and provision of a completely free cavity for the accommodation of ductwork and services.

For Australia, suitable framing profiles can be obtained from Rondo Building Services who provide comprehensive documentation for ceiling framing systems.

The framing system generally consists of a perimeter track profile and steel joists. During the design stage, choosing the right depth of the profile takes into account the maximum allowable span. The main function of the perimeter tracks is to provide friction joints that hold the joists in position until the PROMATECT® board is fitted. They also provide allowance for movement of building structure under ambient conditions. Under fire conditions these tracks allow for the steel joists to expand to minimise deflection of the ceiling construction that may cause excessive cracking and then delamination of the lining boards. This type of joint is suitable for ceiling membrane systems of up to 3000mm span. Track sections should be fixed to the supporting structure using suitable masonry anchors at maximum 500mm intervals. Fixings should be located not more than 100mm from either end of the track section.

For membrane ceilings with a span of more than 3000mm, mounting brackets are required at both ends of the steel joists. The mounting brackets will be attached to the wall, at the same time, and shall be designed to allow for expansion of the steel joists.

See [page 8](#) for further details.

- 1 Wall U-profile
- 2 Horizontal C-profile
- 3 Fixing point

Fixing of primary and secondary profiles



Acoustics In Building

Sound is an energy generated by a source, transmitted through a medium and collected by a receiver. It can be pleasant to be heard, such as music and speeches etc, while some, such as scratching a glass surface with a sharp object, are irritating. This offensive sound is commonly termed noise. The acoustic design of buildings can be divided into two basic requirements, noise control and room acoustics.

Noise control relates to the quantity of sound with an objective to ensure the sound level does not adversely affect the comfort of building occupants. This involves control of sound produced in a room, such as telephones ringing, as well as limiting the noise entering from other rooms or outside the building. A common solution targeting this problem is the introduction of sound absorption systems.

Room acoustics relate to the quality of sound with an objective to enhance the quality of desired sound within a room. This involves factors such as speech intelligibility and perception of musical clarity. The most widely applied solution employed by building designers is the use of a sound insulating system.

A point worth noting is that although both noise control and room acoustics have independent objectives, they are however inter-related in practice. As this manual covers partition and ceiling systems, the following concentrates only on issues related to sound insulation which involves transmission loss (TL) of airborne sound.

Sound Transmission & Classification

The sound transmission loss of a building element, such as a partition, is a measure of how much sound is reduced as it passes through the barrier, expressed in dB or decibels, the unit used to quantify sound. The generally accepted term for the single number ratings for sound transmission loss is the Sound Transmission Class or STC (ASTM E413). This is determined by comparing the TL value to the reference curve in ASTM E413. Generally the higher the STC value, the better the performance of the system. The following table provide a rough idea of what various STC levels mean in terms of privacy afforded.

STC	Privacy afforded
25	Normal speech easily understood
30	Normal speech audible, but unintelligible
35	Loud speech understood
40	Loud speech audible, but unintelligible
45	Loud speech barely audible
50	Shouting barely audible
55	Shouting not audible

Source: U.S. Dept of Commerce/National Bureau of Standards Handbook. "Quieting: A Practical Guide to Noise Control".

Another widely accepted equivalent term is the Weighted Sound Reduction Index or R_w (ISO 717: Part 1 or BS 5821: Part 1). It is determined in a similar manner but instead of TL values, an equivalent Sound Reduction Index (R or R_w), is used.

Note should be taken that results obtained in STC and R_w may have a ± 3 dB deviation from one another.

Most building structures are not built like laboratories and it is very common that the sound insulation rating measured in ideal test conditions will not be achieved in a building. In order to meet the desired level of performance, building designers should therefore carefully consider the compatibility of the selected system with the supporting structure. Note that field performance is typically lower than laboratory performance by approximately 10%.

General Design Considerations

With modern design concepts and technology in building construction, acoustic performance within buildings has become an important element for consideration by building designers. There are many factors involved in establishing an ideal noise level for any particular building space, part of which are as follows:

- To avoid fatigue induced by noise;
- To prevent distraction or disturbance;
- To maintain a good communication & listening environment.

Heavy walls such as concrete have good transmission loss. However, there are some drawbacks which limit its performance. Mass law dictates that a wall will increase its transmission loss by only 5dB for every doubling of mass. Therefore, a single 100mm thick concrete wall of 2300kg/m^3 density might have an STC 45 rating whereas a 200mm thick concrete wall would only achieve STC 50 for a doubling in mass. For most owners and builders, a wall of this size and weight is not desirable. Cost may more than double and the decibel-per-dollar achieved is clearly not acceptable. This limitation can be easily overcome by using a lightweight system, i.e. the partition system, where it is more practical to utilise principals such as air cavity, resilient mountings, sound-absorbing core materials or a combination of these principals without the large increase in mass required for solid walls.

Following are some common practices that are effective for noise control and room acoustics.

1. Double-studding & Air Cavity

With typical drywall partitions, sound striking at the wall surface is transmitted through the first surface material into the wall cavity. It then strikes the opposite wall surface, causing it to vibrate and transmit the sound into the air of the adjoining room. This is termed airborne sound. When the sound strikes the wall at the stud, sound is transmitted direct through the stud and is termed structure borne sound.

The principal of double studding basically means separation of two panels of a drywall partition into a double-leaf wall, integrated with appropriate air spacing (cavity) between the leaves. The introduction of an air-space provides some form of separation or discontinuity between the two wall faces in a double-leaves wall.



As an example, a double stud partition creating an air cavity eliminates direct mechanical connection between the surfaces. The sound transmission is reduced by breaking the sound path. In addition, the air cavity provides vibration isolation between the two sides. Sound in one room striking the one side of the wall causes it to vibrate but because of the mechanical separation and the cushioning effect of the cavity, the vibration of the other side is greatly reduced.

2. Sound-absorbing Core Material

Sound absorption is the effectiveness of a material at preventing the reflection of sound. Generally, the more sound absorption, the fewer echoes will exist. The sound-absorbing core used in the Promat partition designs can be mineral or rock wool, glass wool or polyester, depending upon fire resistance requirements.

These cores will further improve the sound isolation performance of the wall by absorbing sound energy in the cavity before the sound can set the opposite wall surface in motion. They will also provide some damping of the vibrating wall surface.

General Design Considerations

3. Treatment To Flanking Paths

When working with acoustically rated systems, it is critical that strict attention be paid to construction and detailing. The acoustic integrity of a system can be influenced by the combination of elements that make up the system. Single leaf and uninsulated systems are especially more dependent on high quality of installation. For example, if there is a gap of 5mm wide around the perimeter of an STC 45 rated wall of 3m x 3m, the actual performance would degrade to some, STC 30. Therefore to make acoustically rated partitions effective, they must be airtight. Any path for air also means there is a path for sound. In order to achieve the designed STC rating closely, the following factors must also be taken into account:

- Sound paths, e.g. windows, doors, floors and ceilings;
- Penetrations through walls, even above ceilings or below floorings, must be sealed;
- Stagger the joints between multiple layers of wall boards or ceiling linings;
- Do not use power points back to back on either side of a wall;
- Openings for return air in ceiling plenum systems must be strictly controlled.

4. Wall & Floor Intersections

A good acoustical partition is only as good as its joint or intersection at wall and floor, like a chain and its weakest link. If this joint or intersection is not treated properly, the acoustical value may be lost. Many joint defects from flanking paths allow sound to travel via air gaps through the structure.

Acoustical sealants are the simplest means to provide a permanent air-tight seal. They are made from materials that are permanently elastic which will allow floor or wall materials to move, as they are prone to do because of expansion and contraction or outside forces such as structural movement. A permanent air-tight seal is the most effective way to maintain the acoustical integrity of the wall. Regardless of which system is employed, all openings, cracks and material joints should be made air-tight with a permanently elastic acoustical sealant.

System Selection Guide

As sound insulation requirements may vary from country to country, the table below suggests acoustic values for some typical partition installations, unless otherwise specified by the architects. Please consult Promat for more information.

STC rating			Applications for separating
Minimum	Average	Luxury	
45dB	50dB	55dB	Bedroom to bedroom
50dB	55dB	60dB	Bedroom to living room
50dB	55dB	60dB	Bedroom to lobby
45dB	50dB	55dB	Office to office
40dB	45dB	50dB	Office to general area
45dB	50dB	55dB	Office to conference room
45dB	50dB	55dB	Office to washroom
40dB	45dB	50dB	Conference room to general area
40dB	45dB	50dB	Conference room to conference room
45dB	-	-	Classroom to classroom
55dB	-	-	Classroom to shop
45dB	-	-	Classroom to recreation area
60dB	-	-	Classroom to music room

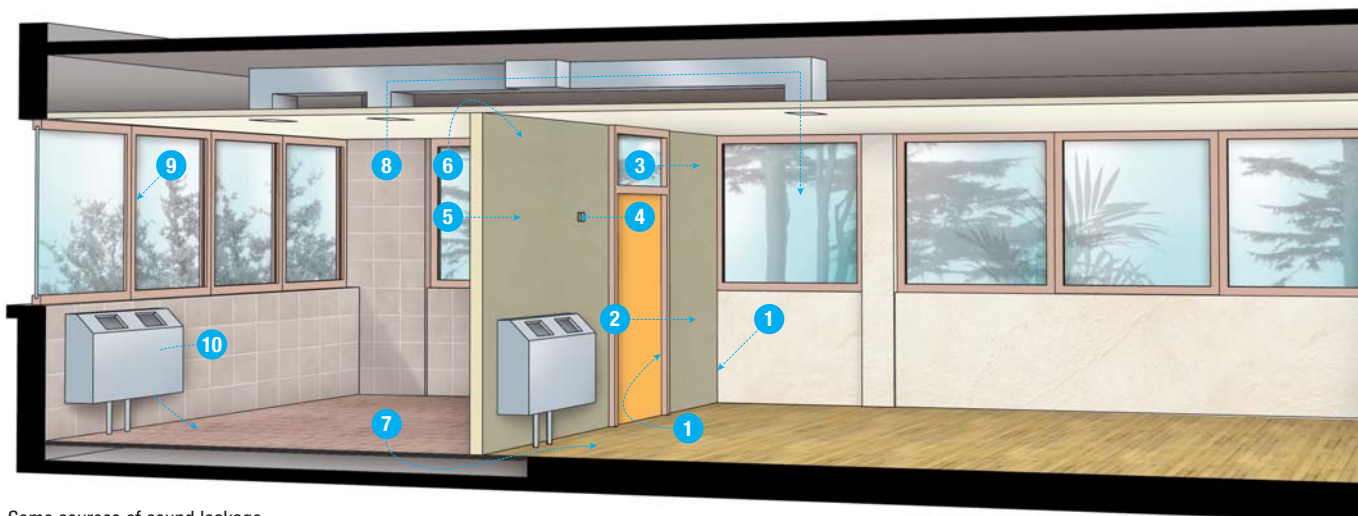

Some sources of sound leakage

- 1** Air leaks through gaps or cracks
- 5** Partition performance
- 8** Common ventilation system without sound absorbents treatment
- 2** Doors
- 6** Sound transmission via suspended ceilings or partitions
- 9** Lightweight mullion or partition closer
- 3** Light weight panels above doors
- 7** Common floor heating duct
- 10** Appliances
- 4** Electrical outlets and service pipes



Fire attack from below / Non loadbearing



Fire Rating	FRL	-/120/120
	STANDARD	AS1530: Part 4: 2005
	APPROVAL	BRE: CC 232157A
Acoustic	# STC # R _w	36dB 36dB
	STANDARD	ISO140: Part 3: 1996 ISO717: Part 1: 1996
	PREDICTED ASSESSMENT	Marshall Day 16th Aug 2007
Construction	MAXIMUM SPAN	3000mm
	CEILING THICKNESS	From 150mm
	CEILING MASS	From 39kg/m ²

Margin of error is generally within ±3dB.

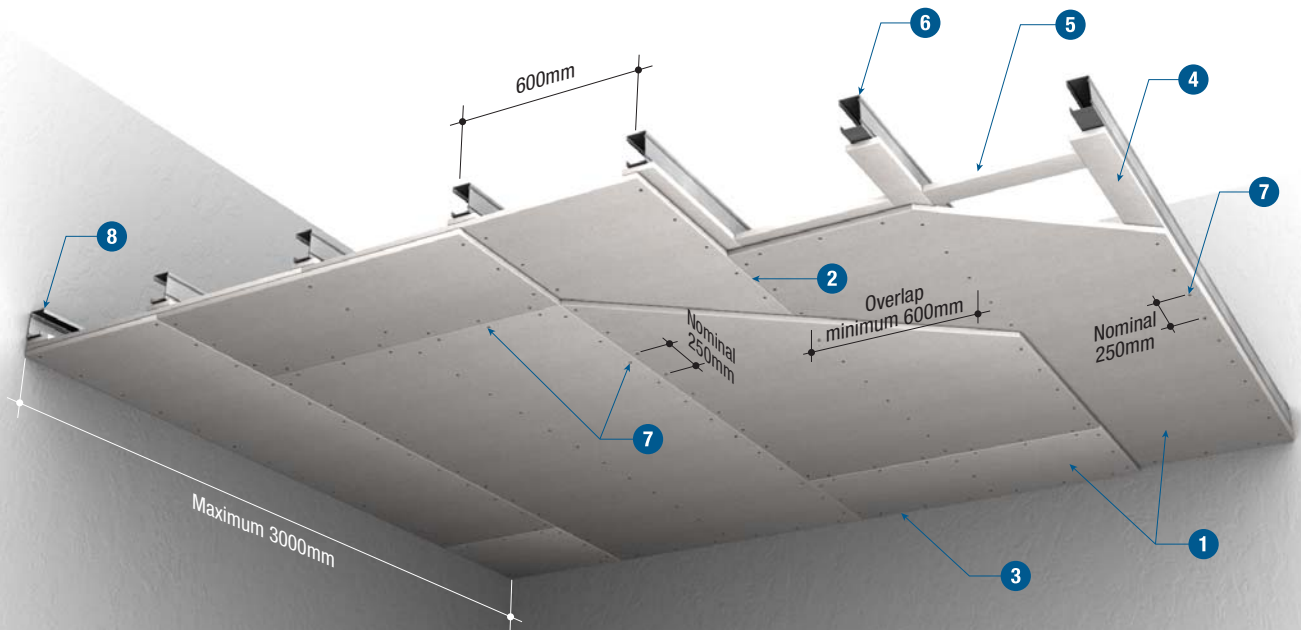

TECHNICAL DATA

- | | |
|---|---|
| <ul style="list-style-type: none"> 1 2 layers of PROMATECT® 100 board 20mm thick each 2 All longitudinal board joints must be coincident with the steel framework, longitudinal board joints between the 2 layers must be staggered by 600mm 3 Gap at perimeter to be caulked with PROMASEAL® AN Acrylic Sealant 4 1 layer of PROMATECT® 100 cover strip 85mm x 20mm thick 5 1 layer of PROMATECT® 100 cover strip 50mm x 20mm thick at transverse joints in the 1st layer | <ul style="list-style-type: none"> 6 Steel joist at 600mm centres 7 No. 8 steel screws at nominal 250mm centres <ul style="list-style-type: none"> • 32mm long to secure cover strips to steel • 50mm long to secure 1st layer board to steel • 72mm long to secure 2nd layer board to steel • 35mm long laminating screws to stitch transverse joints in 2nd layer board to 1st layer board 8 Steel wall channel <p>Please refer to pages 8 and 9 for perimeter details and control joints.</p> |
|---|---|

System Specification

Ceilings are to be constructed using 2 layers of 20mm thick PROMATECT® 100 matrix engineered mineral boards all in accordance with the Architectural Specification in the manufacturer's handbook. Relevant constructions are to be selected according to the required FRL of -/120/120 (fire from below) of the selected elements. All printed installation details are to be followed to ensure approval to AS1530: Part 4. All work to be certified by installer in an approved manner.



Ceiling perimeter to wall intersection (case 1)

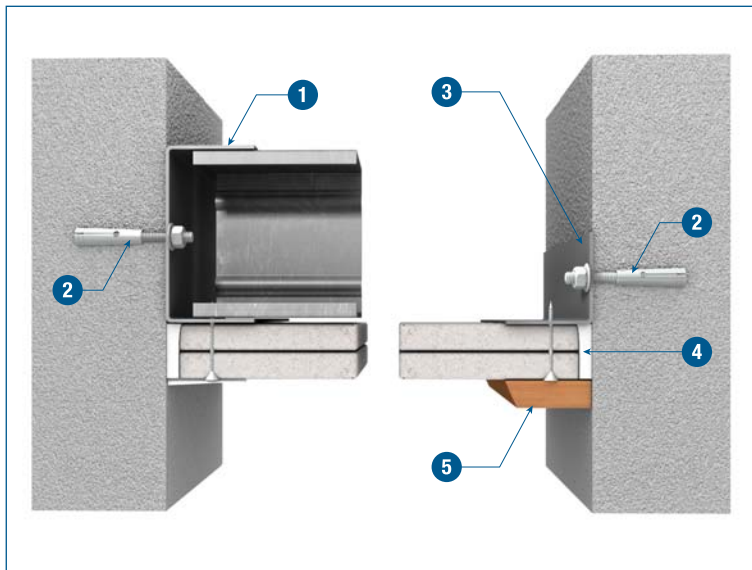

TECHNICAL DATA

Please refer to page 7 for applicable system and FRL.

- 1 Galvanised steel perimeter channel
- 2 50mm x M6 expansion bolts at 500mm centres
- 3 Galvanised steel perimeter angle
- 4 PROMASEAL® AN Acrylic Sealant to maintain the fire and acoustic performance
- 5 Ceiling trim or coving to perimeter

Ceiling perimeter to wall intersection (case 2)

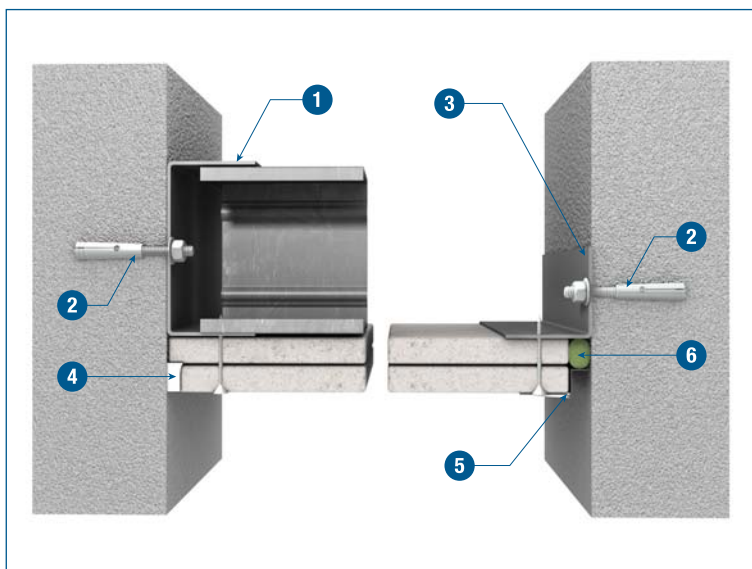

TECHNICAL DATA

Please refer to page 7 for applicable system and FRL.

- 1 Galvanised steel perimeter channel
- 2 50mm x M6 expansion bolts at 500mm centres
- 3 Galvanised steel perimeter angle
- 4 PROMASEAL® AN Acrylic Sealant to maintain the fire and acoustic performance
- 5 RONDO P50 Shadowline Trim and set over
- 6 PROMASEAL® IBST™ of Ø 22mm diameter to maintain the fire performance (not suitable where acoustic integrity is required)

Suspended ceiling perimeter to wall intersection

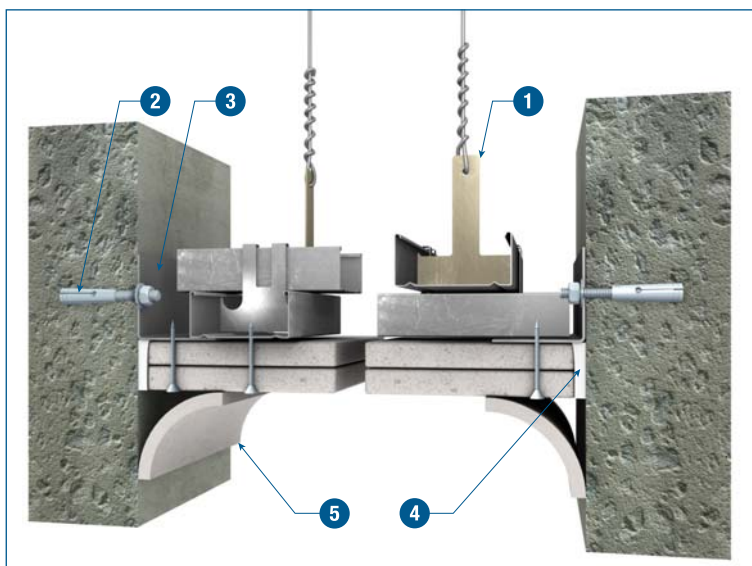

TECHNICAL DATA

Please refer to page 7 for applicable system and FRL.

- 1 Concealed grid suspended ceiling system
- 2 50mm x M6 expansion bolts at 500mm centres
- 3 Galvanised steel perimeter angle
- 4 PROMASEAL® AN Acrylic Sealant to maintain the fire and acoustic performance
- 5 Ceiling trim or coving to perimeter



Parallel to steel framing (single layer)

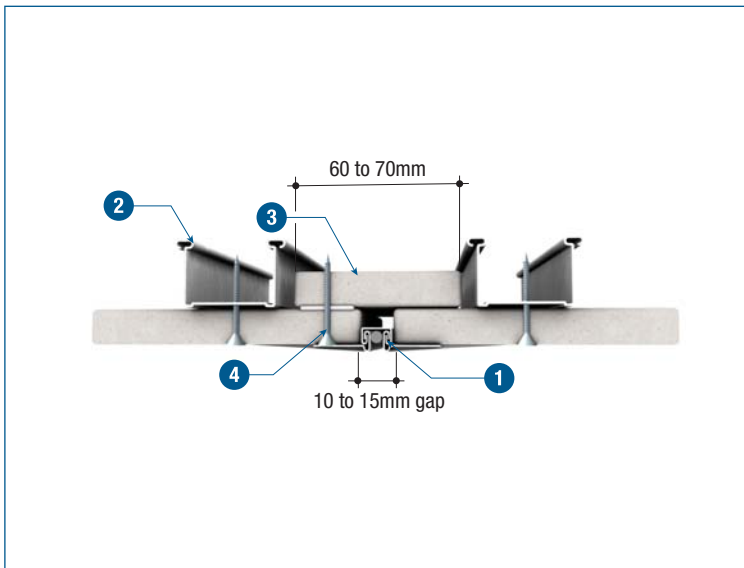

TECHNICAL DATA

Please refer to page 7 for applicable system and FRL.

- 1 RONDO P35 control joint with set finish
- 2 Concealed steel grid framing sections
- 3 Continuous PROMATECT® 100 board strips
- 4 Fix one side of PROMATECT® 100 board strips with laminating screws at 200mm centres

Parallel to steel framing (double layer)

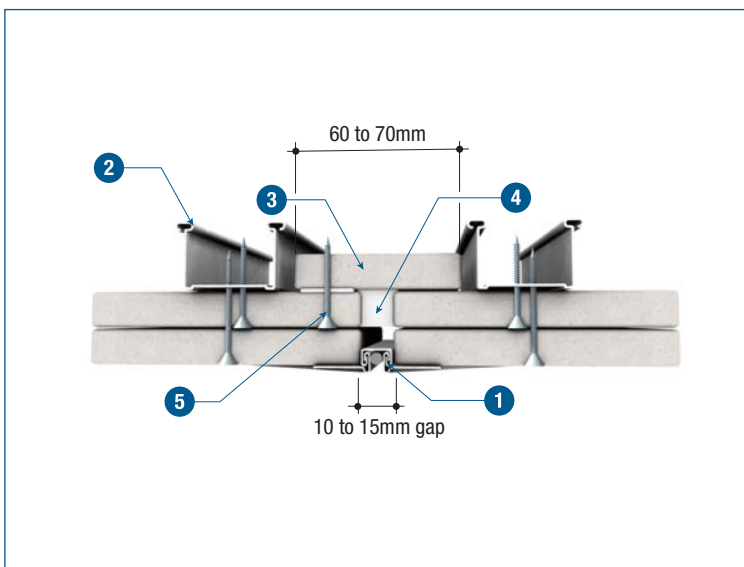

TECHNICAL DATA

Please refer to page 7 for applicable system and FRL.

- 1 RONDO P35 control joint with set finish
- 2 Concealed steel grid framing sections
- 3 Continuous PROMATECT® 100 board strips
- 4 Continuously fill gap with PROMASEAL® AN Acrylic Sealant to minimum depth of 1st layer board thickness
- 5 Fix one side of PROMATECT® 100 board strips with laminating screws at 200mm maximum centres or plaster based adhesive

Perpendicular to steel framing (double layer)

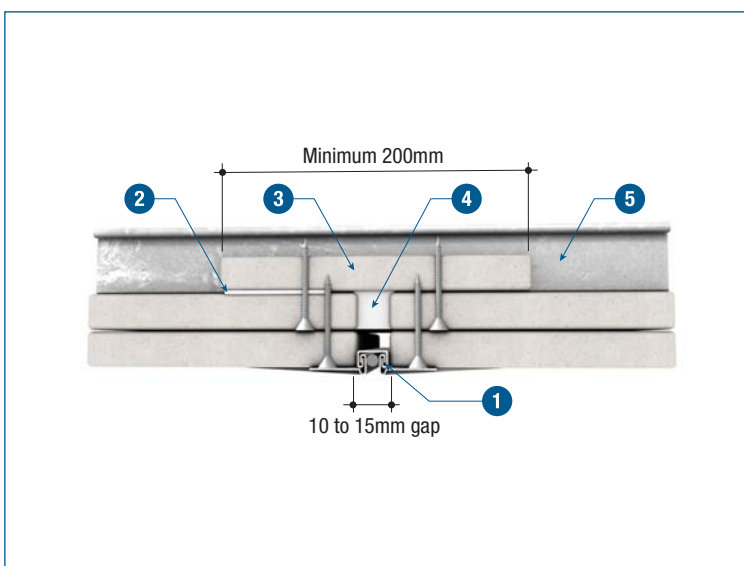

TECHNICAL DATA

Please refer to page 7 for applicable system and FRL.

- 1 RONDO P35 control joint with set finish
- 2 Fix one side of PROMATECT® 100 board strips with laminating screws at 200mm maximum centres or plaster based adhesive
- 3 PROMATECT® 100 strips between galvanised steel channel
- 4 Continuously fill gap with PROMASEAL® AN Acrylic Sealant to minimum depth of 1st layer board thickness
- 5 Continuous galvanised steel channel



Architectural Specification

The following are standard architectural specifications for ceiling systems using PROMATECT® 100. The designer must determine the suitability of the design to the application and requirements before undertaking or constructing any works relating to the specifications and where in doubt should obtain the advice of a suitably qualified engineer.

Fire Attack From Below / Non Loadbearing

120 minutes fire rating, integrity and insulation in accordance with the criteria of [AS1530: Part 4: 2005](#). Non loadbearing.

Supporting Structure

Care should be taken that any structural element by which the ceiling system is supported, e.g. steel stud, perimeter steel channel, has at least fire resistance of 120 minutes and is capable of supporting the ceiling membrane system for the required period.

Lining Boards

2 layers of 20mm PROMATECT® 100 matrix engineered mineral boards as manufactured by Promat International (Asia Pacific) Ltd. All joints to coincide with steel framing. Standard board dimensions 1200mm x 2500mm x 20mm.

Fixing

Wall tracks are anchored to the wall using 60mm x M6 steel expanding anchors at maximum 500mm centres. Ceiling joists comprising steel lipped channels are then positioned at 600mm maximum centres. The ends of each of the steel joists are friction fitted between the flanges of the steel perimeter channels. Wall tracks and ceiling joists section sizes are to be selected as appropriate according to the ceiling span according to the steel joist table below.

Steel Joist Table

Ceiling span	Proposed steel joist	Proposed wall tracks
Up to 1.5m	Lipped C-92 x 35mm x 5mm x 0.55mm	C-94 x 32mm x 0.55mm
Up to 2.0m	Lipped C-92 x 35mm x 5mm x 1.15mm	C-94 x 32mm x 0.55mm
Up to 2.5m	Lipped C-102 x 51mm x 12.5mm x 1.2mm	C-100 x 40mm x 0.6mm
Up to 3.0m	Lipped C-102 x 51mm x 12.5mm x 1.5mm	C-100 x 40mm x 0.6mm

The underside of the steel joists and the perimeter channels are covered with 20mm thick PROMATECT® 100 fillets, minimum width 50mm for the perimeter channels and 85mm for the steel joists. The fillets are fixed in position using minimum 32mm x No.8 screws at 250mm centres.

A layer of 20mm thick PROMATECT® 100 boards is then fixed to the topside of the steel framework and fillets using minimum 50mm x No.8 screws at maximum 250mm centres. All longitudinal board joints must be coincident with the steel framework. Transverse joints in the boards are backed with PROMATECT® 100 cover strips, 20mm thick x 50mm wide. The second layer is fixed in a similar manner using minimum 72mm x No.8 screws, ensuring that all joints in the two layers are staggered by 600mm.

Tests & Standards

Along with all material tests the complete system along with the framing is tested and assessed in accordance with the criteria of AS1530: Part 4.

Jointing

Plain butt joints between machined edges of boards. ⁽¹⁾

Joints filled in preparation for painting. ⁽²⁾

Joints filled and taped in preparation for decoration. ⁽³⁾

Follow-on Trades

Surface of boards to be prepared for painting/plastering/tiling⁽⁴⁾ in accordance with manufacturer's recommendations.

NOTES:

- ^{(1), (2), (3), (4)} delete as appropriate.
- The above ceiling is approved for spans up to 3000mm using framing members as detailed.
- Perimeter gaps will be filled with fire resistant PROMASEAL® AN Acrylic Sealant.

For latest information of the Promat Asia Pacific organisation, please refer to www.promat-ap.com

ASIA PACIFIC HEADQUARTERS

Promat International (Asia Pacific) Ltd.
Unit 19-02-01, Level 2 PNB Damansara
No.19 Lorong Dungun, Damansara Heights
50490 Kuala Lumpur
MALAYSIA
Tel: +60 (3) 2095 5111
Fax: +60 (3) 2095 6111
Email: info@promat-ap.com

AUSTRALIA

Promat Australia Pty. Ltd.
1 Scotland Road, Mile End South
Adelaide, SA 5031
Tel: +61 1800 PROMAT
Fax: +61 (8) 8352 1014
Email: mail@promat.com.au

New South Wales Office
Promat Australia Pty. Ltd.
Unit 1, 175 Briens Road
Northmead, NSW 2152
Tel: +61 1800 PROMAT
Fax: +61 (2) 9630 0258
Email: mail@promat.com.au

Victoria Office
Promat Australia Pty. Ltd.
3/273 Williamstown Road
Port Melbourne, VIC 3207
Tel: +61 1800 PROMAT
Fax: +61 (3) 9645 3844
Email: mail@promat.com.au

Western Australia Office
Promat Australia Pty. Ltd.
Locked Bag 8
Subiaco, WA 6904
Tel: +61 1800 PROMAT
Fax: +61 1800 33 45 98
Email: mail@promat.com.au

CHINA

Promat China Ltd.
Room 503, Block B, Qi Lin Plaza
13-35 Pan Fu Road
510180 Guangzhou
Tel: +86 (20) 8136 1167
Fax: +86 (20) 8136 1372
Email: info@promat.com.cn

Beijing Office
Promat North China
(Division of Promat China Ltd.)
Room 1507 Building 5, SOHO Xiandaicheng
No.88 Jianguo Road, Chaoyang District
100022 Beijing
Tel: +86 (10) 8589 1254
Fax: +86 (10) 8589 2904
Email: info@promat.com.cn

HONG KONG

Promat International (Asia Pacific) Ltd.
Room 1010, C.C. Wu Building
302-308 Hennessy Road
Wanchai
Tel: +852 2836 3692
Fax: +852 2834 4313
Email: apromath@promat.com.hk

INDIA

Promat International (Asia Pacific) Ltd.
(India Representative Office)
610-611, Ansal Imperial Tower
C-Block, Community Centre
Naraina Vihar, Naraina
110028 New Delhi
Tel: +91 (11) 2577 8413 (general)
+91 (99) 6705 0813 (west area)
+91 (99) 8994 0505 (south area)
Fax: +91 (11) 2577 8414
Email: info-india@promat-asia.com

MALAYSIA

Promat (Malaysia) Sdn. Bhd.
Unit 19-02-01, Level 2 PNB Damansara
No.19 Lorong Dungun, Damansara Heights
50490 Kuala Lumpur
Tel: +60 (3) 2095 8555
Fax: +60 (3) 2095 2111
Email: info@promat.com.my

SINGAPORE

Promat Building System Pte. Ltd.
10 Science Park Road, #03-14 The Alpha,
Singapore Science Park II
Singapore 117684
Tel: +65 6776 7635
Fax: +65 6776 7624
Email: info@promat.com.sg

VIETNAM

Promat International (Asia Pacific) Ltd.
(Vietnam Representative Office)
Room 606 Giay Viet Plaza
180-182 Ly Chinh Thang Street
Ward 9, District 3, Hochiminh City
Tel: +84 (8) 931 5964 (south area)
+84 (4) 565 8101 (north area)
Fax: +84 (8) 931 5964 (south area)
+84 (4) 565 8677 (north area)
Email: thai@promat-asia.com (south area)
trangoc@promat-asia.com (north area)

Your local Promat supplier

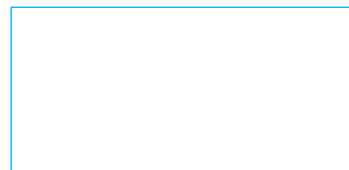

For Promat International groups worldwide: www.promat-international.com

1. This document is formulated on the basis of information and experience available at the time of preparation. Promat is constantly reviewing and updating all of its test data and reserves the right to change specifications without notice.
2. Promat is not responsible if recipients of fire test reports, assessments or literature incorrectly interpret their contents and use products based on those interpretations.